

SEPAR FILTER

SEPAR 2000

SWK 2000/5/U

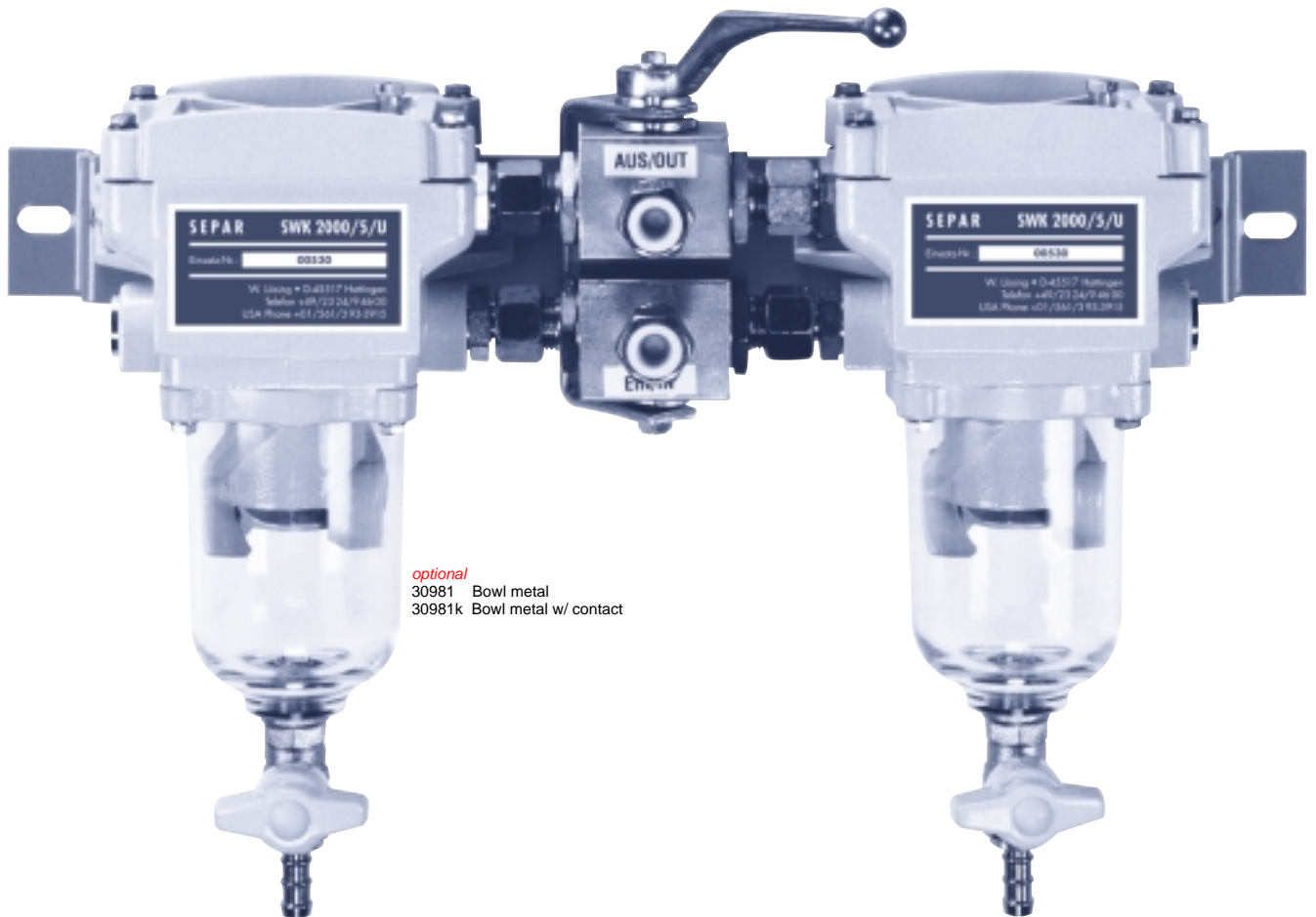

optional
30981 Bowl metal
30981k Bowl metal w/ contact

POS.	ARTIKEL-NR. ARTICLE NR.	STÜCK PIECES	BENENNUNG	DESCRIPTION	POS.	ARTIKEL-NR. ARTICLE NR.	STÜCK PIECES	BENENNUNG	DESCRIPTION
1	30408	2	Entlüftungsschraube	bleed valve	15	40002	2	Dichtung	gasket
2	30430	8	Schraube (Deckel)	screw (lid)	16	30366	2	Ablafshahn	drain cock
3	30542	2	Deckel	lid	17	30560	2	Schraube	screw
4	30545	2	Deckeldichtung	lid gasket	18	30558	2	Dichtung f. Pos. 1	gasket f. Pos. 1
5	30295	2	Federkassette	spring cassette	19	30472	8	Dichtung f. Pos. 13	gasket f. Pos. 13
6	00530	2	Filter-Einsatz	filter element	20	30133	4	Schraube	screw
7	30447	16	U-Scheibe	washer	21	30022	4	Sicherungsmutter	lock nut
8	30541	2	Gehäuse	housing	22	30021	8	U-Scheibe	washer
9	30565	2	Dichtung Bowlenhaltering	bowl gasket	23	30473	4	Ger.Verschraubung	straight fitting
10	30564	2	Bowlenhaltering	bowl retainer ring	24	30474	1	Umschaltventil	reversing valve
11	30548	2	Zentrifuge	centrifuge	25	30475	1	Montageplatte	mounting plate
12	30561	8	Schraube (Bowlenhaltering)	screw (for bawl retainer ring)	26	30490	1	Umlenkehebel	reversing lever
13	30471	4	Verschluß-Stopfen	blind screw	27	30249	2	Ü-Mutter	union nut
14	30984	2	Bowle	bowl	28	30250	2	Schneidring	cutting ring

SEPAR FILTER

SEPAR 2000

SWK 2000/5/U

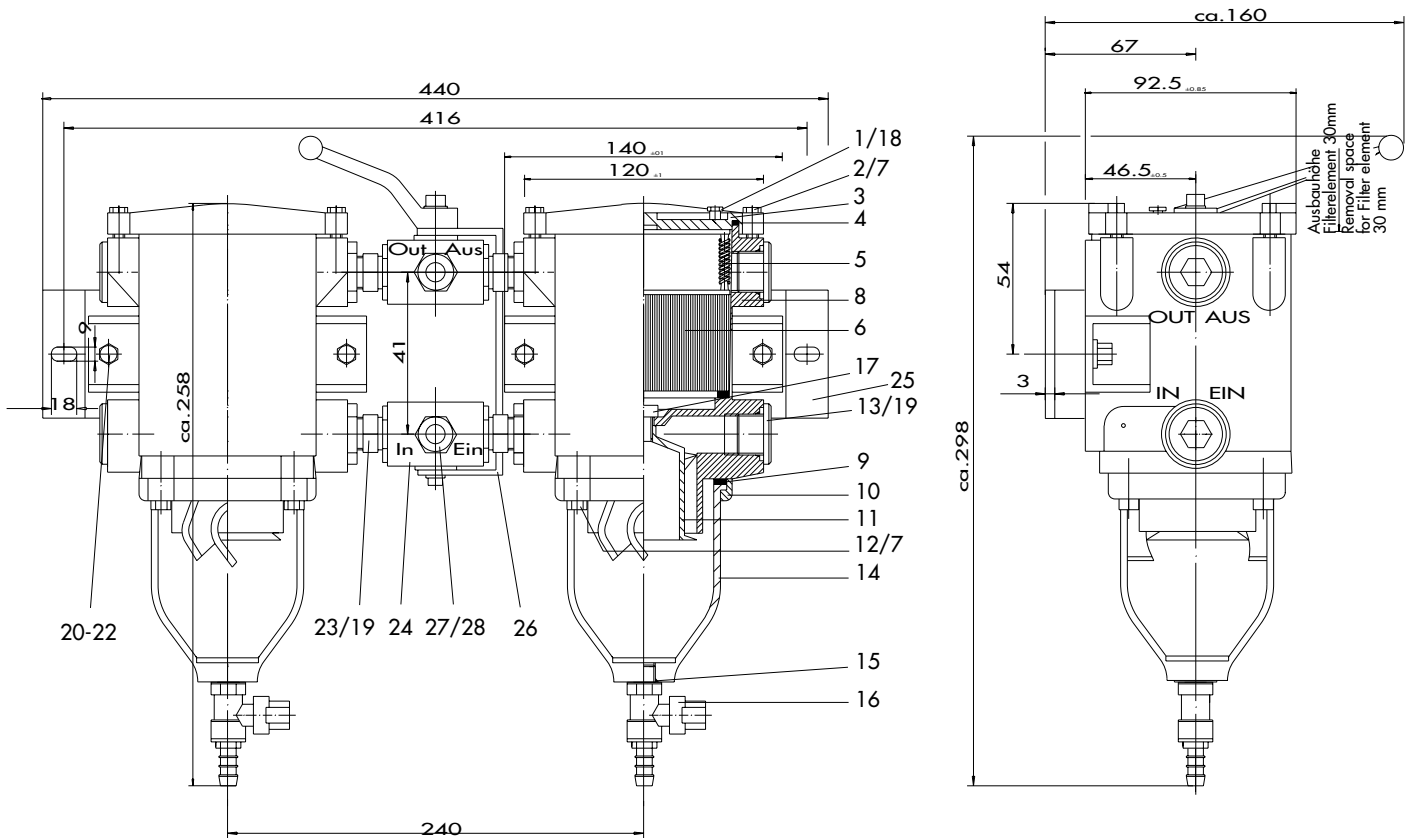

FLUSSDIAGRAMM · FLOW DIAGRAMM

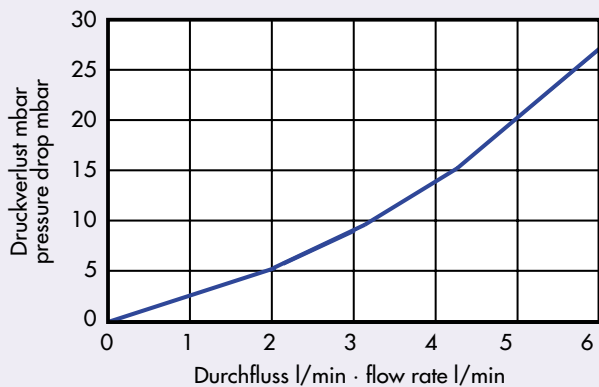

Technische Änderungen vorbehalten
We reserve the right to make technical changes without notification

Willibrord Lösing
Filter-Technik



Postfach 86 6009
45517 Hattingen
Essener Straße 108
45529 Hattingen
Telefon 02324/94600
Telefax 02324/40842

Max. Durchflussmenge: 5 l/min Anschluss: 12 mm Rohr Ø
Max. flow rate: 5 l/min Connection: 12 mm Pipe Ø